

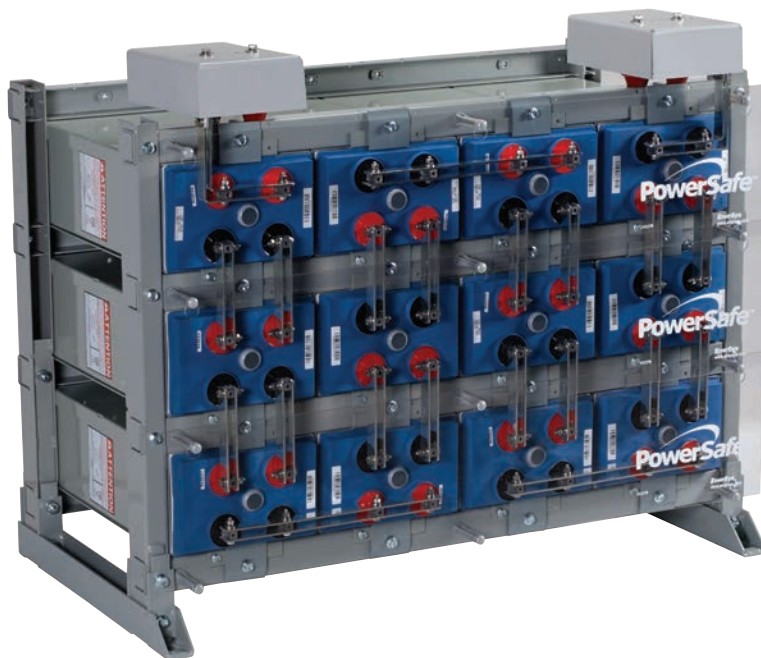

PowerSafe[®]
DDm UBC System

Battery Installation Manual



PowerSafe[®] DDm Modular Battery Systems

IMPORTANT!
Read safety information first

See Safety, Storage, Operating and
Maintenance Manual

Visit us at www.enersys.com



Publication No: US-DDM-IM-AA June 2016

The installation manual is for reference only. To maximize safety and performance, read the accompanying Safety, Storage, Operating and Maintenance Manual thoroughly. It provides full instructions regarding safety, storage, operation and maintenance. Failure to observe the precautions as presented may result in injury or loss of life.

This document is proprietary to EnerSys[®]. This document cannot be copied or reproduced in whole or in part, nor can its contents be revealed in any manner or to any person except to meet the purpose for which it was delivered, without the express written permission of EnerSys.

Please check our website for literature updates.

www.enersys.com

GENERAL SAFETY INSTRUCTIONS

Warnings in this manual appear in any of three ways:



Danger

The danger symbol is a lightning bolt mark, enclosed in a triangle. The danger symbol is used to indicate imminently hazardous situations, locations and conditions which, if not avoided, WILL result in death, serious injury and/or severe property damage.



Warning

The warning symbol is an exclamation mark enclosed in a triangle. The warning symbol is used to indicate potentially hazardous situations and conditions, which, if not avoided COULD result in serious injury or death. Severe property damage COULD also occur.



Caution

The caution symbol is an exclamation mark enclosed in a triangle. The caution symbol is used to indicate potentially hazardous situations and conditions, which, if not avoided may result in injury. Equipment damage may also occur.

Other warning symbols may appear along with the Danger and Caution symbols and are used to specify special hazards. These warnings describe particular areas where special care and/or procedures are required in order to prevent serious injury and possible death:



Electrical warnings

The electrical warning symbol is a lightning bolt mark enclosed in a triangle. The electrical warning symbol is used to indicate high voltage locations and conditions, which may cause serious injury or death if the proper precautions are not observed.



Explosion warnings

The explosion warning symbol is an explosion mark enclosed in a triangle. The explosion warning symbol is used to indicate locations and conditions where molten or exploding parts may cause serious injury or death if the proper precautions are not observed.

GENERAL SAFETY INSTRUCTIONS



A battery can present a risk of electrical shock and high short circuit current.

The following precautions should be observed when working with batteries.

1. Verify that the Uninterruptible Power Supply (UPS) is off and that the power cord is disconnected from the power source.
2. Remove watches, rings or other metal objects.
3. Use tools with insulated handles to prevent inadvertent shorts.
4. Wear rubber gloves and boots.
5. Do not lay tools or metal parts on top of batteries.
6. Determine if the battery is inadvertently grounded. If inadvertently grounded, remove source of ground. Contact with any part of a grounded battery can result in electrical shock. The likelihood of such shock will be reduced if such grounds are removed during installation and maintenance.
7. Verify circuit polarities before making connections.
8. Disconnect charging source and load before connecting or disconnecting terminals.
9. Valve Regulated Lead Acid (VRLA) batteries contain an explosive mixture of hydrogen gas. Do not smoke, cause a flame or spark in the immediate area of the batteries. This includes static electricity from the body.
10. Use proper lifting means when moving batteries and wear all appropriate safety clothing and equipment.
11. Do not dispose of lead acid batteries except through channels in accordance with local, state and federal regulations.

GENERAL SAFETY INSTRUCTIONS

Save these instructions

This manual contains important instructions for PowerSafe® DDM Lead Acid Battery Systems that should be followed during the installation and maintenance of the battery system.

Only a qualified service representative who is knowledgeable in batteries and the required precautions should perform servicing of the batteries. Keep unauthorized personnel away from batteries.



Caution

Misuse of this equipment could result in human injury and equipment damage. In no event will EnerSys be responsible or liable for either indirect or consequential damage or injury that may result from the use of this equipment.



Caution

Do not dispose of the batteries in a fire. The batteries may explode.



Caution

Do not open or mutilate the batteries. Released electrolyte is harmful to the eyes and skin and may also be toxic.



Warning

This unit contains sealed lead acid batteries. Lack of preventative maintenance could result in batteries exploding and emitting gasses and/or flame. An authorized, trained technician must perform annual preventative maintenance.



Warning

Failure to replace a battery before it becomes exhausted may cause the case to crack, possibly releasing electrolyte from inside the battery and resulting in secondary faults such as odor, smoke and fire.



Warning

Proper maintenance to the battery system of this unit must be done by a qualified service technician. This is essential to the safety and reliability of your Uninterruptible Power Supply (UPS) system.

IMPORTANT

Read safety information first

See Safety, Storage, Operating and Maintenance Manual

TABLE OF CONTENTS

| | |
|--|----|
| GENERAL SAFETY INSTRUCTIONS | 1 |
| GENERAL INFORMATION | 6 |
| RECOMMENDED INSTALLATION EQUIPMENT AND SUPPLIES | 8 |
| SYSTEM LAYOUT | 9 |
| Anchor Spacing | 10 |
| FRAME ASSEMBLY AND INSTALLATION | 11 |
| Base Beams | 11 |
| Vertical Channels | 11 |
| Horizontal Channels | 12 |
| Cell Support Shelves | 14 |
| BATTERY CELL INSTALLATION | 15 |
| Module Retainers | 16 |
| Electrical Bonding Instructions | 16 |
| CONNECTIONS | 17 |
| Terminal Plates | 17 |
| Inter-Cell Connectors | 18 |
| Terminal Bars | 19 |
| INITIAL SYSTEM READINGS | 20 |
| SAFETY SHIELDS AND COVERS | 21 |
| Safety Shields | 21 |
| Terminal Plate Covers | 21 |

GENERAL INFORMATION

PowerSafe® DDm battery systems are modular units that can be installed in a SINGLE STACK (Figure 1), a MULTI-STACK (Figure 2), or a MULTI-STACK ZERO SEPARATION (Figures 3A and 3B).

Systems are available in 24, 48 and other voltage configurations. These systems allow for assembly at remote locations.

See the ASSEMBLY DRAWING to determine the configuration for your installation.

Before installation: Verify items received versus Bill of Lading. Verify parts against system Bill of Materials.

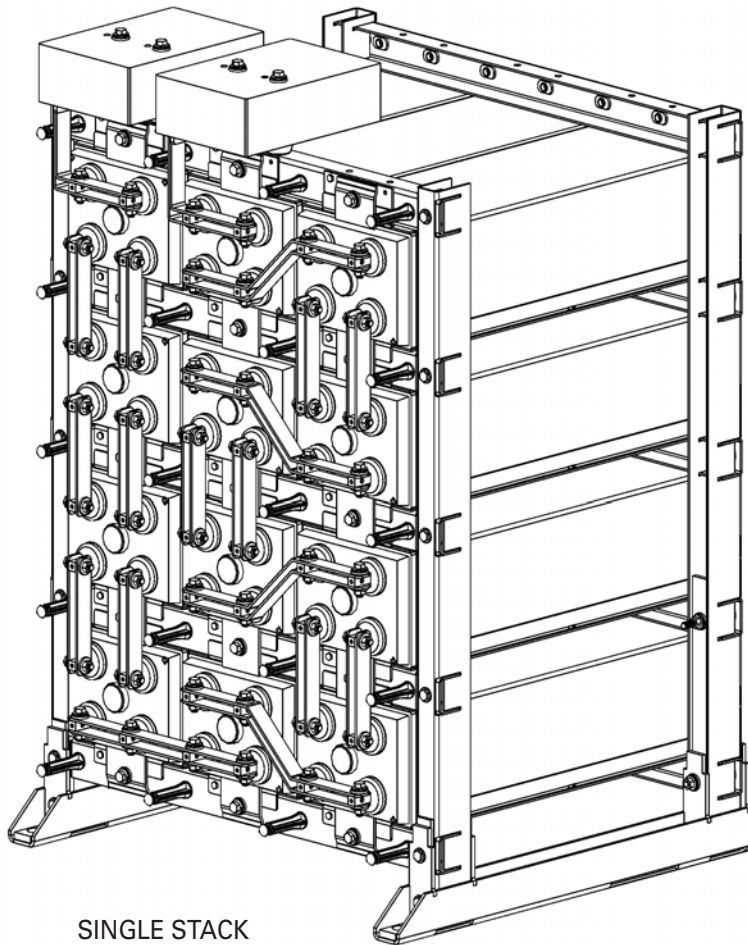

SINGLE STACK
FIGURE 1

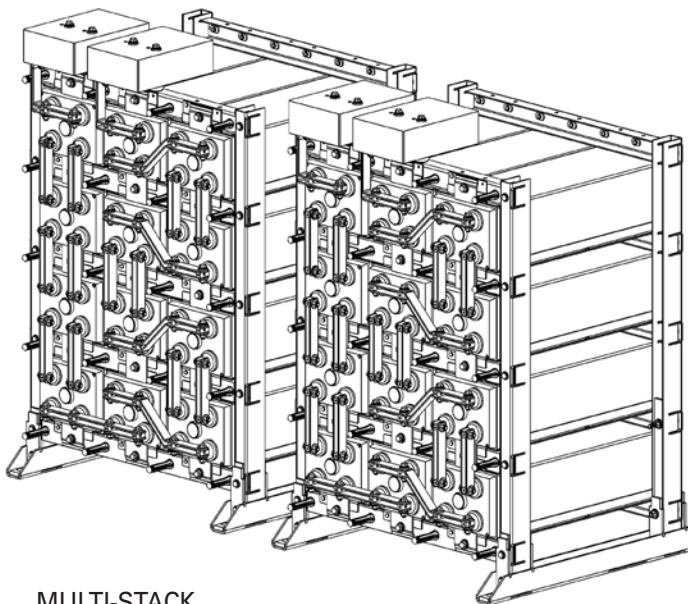

MULTI-STACK
FIGURE 2

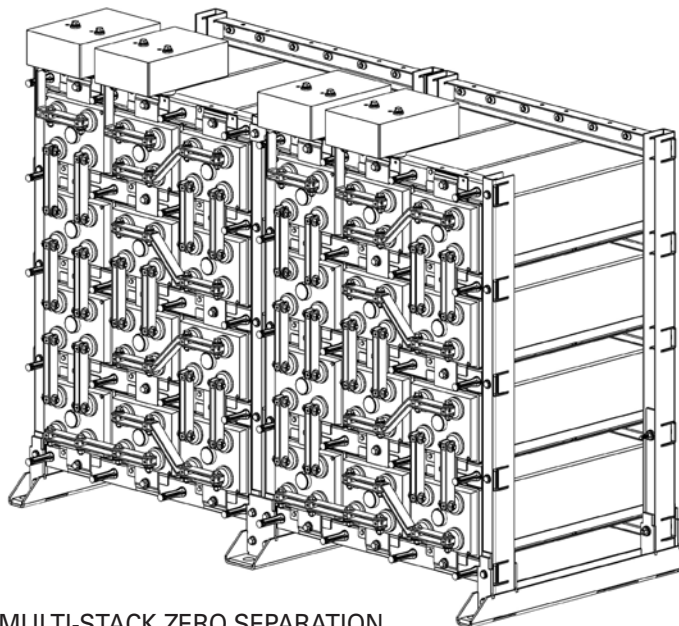

MULTI-STACK ZERO SEPARATION
FIGURE 3A

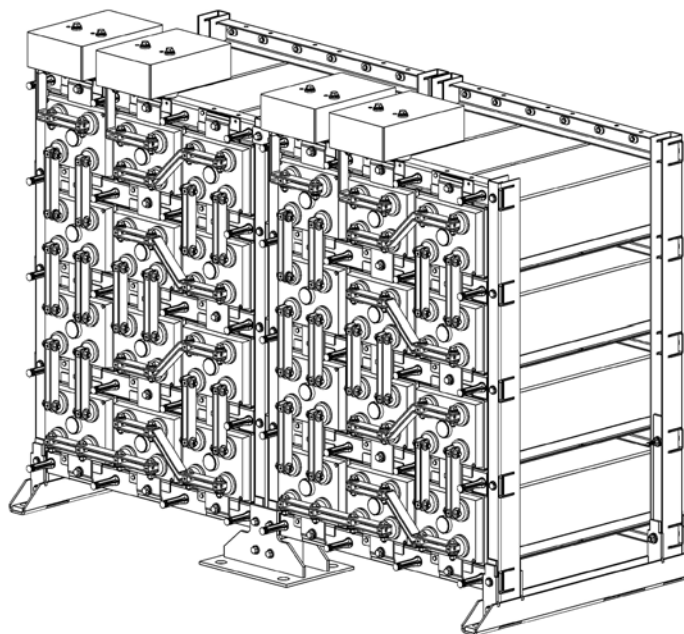

MULTI-STACK ZERO SEPARATION
FIGURE 3B

RECOMMENDED INSTALLATION EQUIPMENT AND SUPPLIES

Before working with the battery system, be sure that you have the proper protective clothing, safety equipment and insulated tools as specified in the Safety, Storage, Operating and Maintenance Manual for the VRLA Modular Battery Systems.

The following is a recommended list of equipment required for installation of a PowerSafe® DDM Battery System.

| TABLE 1 | |
|---|------------------|
| EQUIPMENT REQUIRED | CHECK IF ON HAND |
| Chalk Line | |
| Torpedo Level (Plastic) | |
| Torque Wrench (10-200 in-lbs) (SAE and Metric) | |
| Torque Wrench (50-100 ft-lbs) (SAE and Metric) | |
| Floor Anchors (User-supplied per battery system) | |
| Floor Shims (User-supplied) | |
| Drive Ratchet Wrench with Minimum 3" Extension (SAE and Metric) | |
| Box Wrenches (SAE and Metric) | |
| Screwdrivers | |
| Wipes, Paper or Cloth | |
| Stiff Bristle Nonmetallic Brush/Pad | |
| Tape Measure (Nonmetallic) | |
| Safety Equipment and Clothing | |
| Small Paintbrush | |
| Standard Allen Wrench Set | |



Be sure you have all the proper protective clothing, safety tools and equipment on hand before starting the installation.

SYSTEM LAYOUT

Before installing the battery system, lay out available floor space including aisles for installation, maintenance and possible cell replacement. Consult the local installation considerations as determined in Section 5 of the Safety, Storage, Operating and Maintenance Manual for the VRLA Modular Battery Systems. Recommended minimum clearance between these racks and any objects (including walls and equipment) is 4 inches (102 mm).

1. Layout the system position for either a SINGLE STACK (Figure 4), a MULTI-STACK (Figure 5), or MULTI-STACK WITH ZERO SEPARATION (Figures 6, 7 and 8) configuration with the dimensions defined in Table 2.
2. Locate the position of the floor anchors using the frame base beams.

NOTE:

- Floor anchoring is **REQUIRED** for all installations.
- Allow sufficient clearance between adjacent walls or equipment for proper installation of anchors. Please check your local codes for clearances required.
- Floor anchor design (including, but not limited to size, quantity and capacity) and installation are the responsibility of the user/installer.
- Follow the user's design and the manufacturer's instructions.

3. Mark floor with the position of the floor anchors.

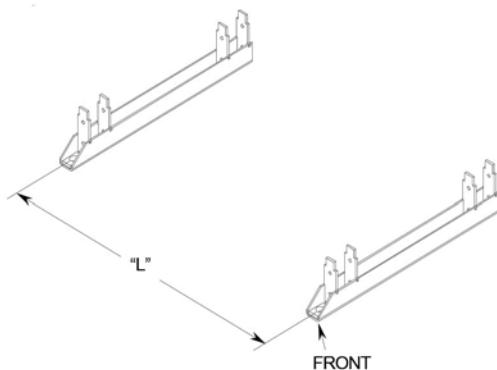

SINGLE STACK
FIGURE 4

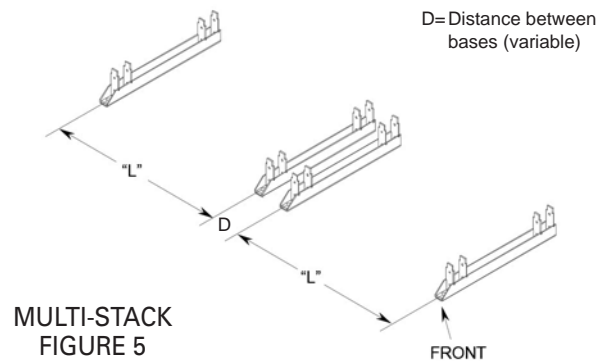

MULTI-STACK
FIGURE 5

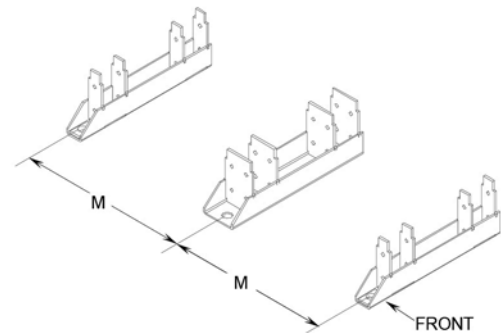

DDm35/50 MULTI-STACK WITH ZERO SEPARATION
FIGURE 6

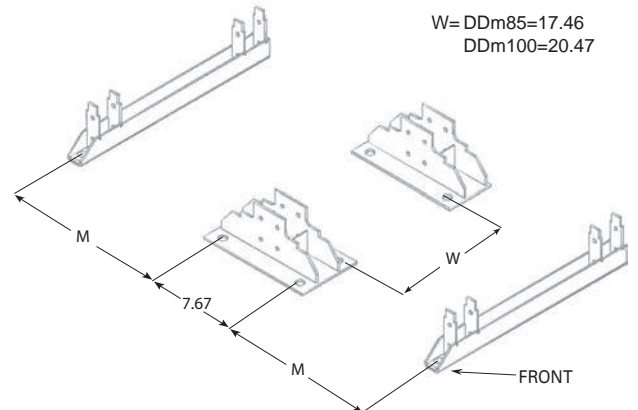

DDm85/100 MULTI-STACK WITH ZERO SEPARATION
FIGURE 7

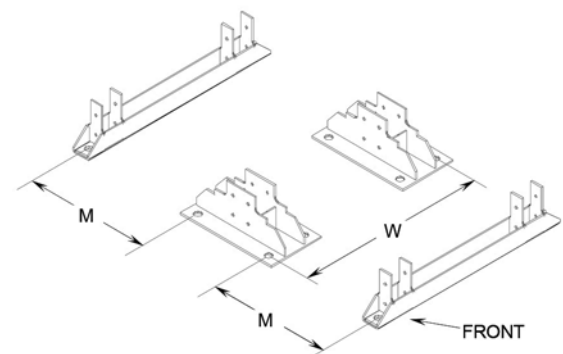

DDm125 MULTI-STACK WITH ZERO SEPARATION
FIGURE 8

Anchor Spacing

| TABLE 2 Base Beam Anchor Spacing | | | | | |
|---|---------------------|---------------------|---------------------|---------------------|--------------------------------------|
| Cell Model | 2 Cells Wide | 3 Cells Wide | 4 Cells Wide | 6 Cells Wide | Multi-Stack w/zero separation |
| | L (in) | L (in) | L (in) | L (in) | M (in) |
| 35-07 | 6.04 | N/A | 10.52 | 15.01 | L+0.89 |
| 50-09 | 9.04 | N/A | 16.52 | 24.01 | L+0.89 |
| 50-13 | 12.04 | N/A | 22.52 | 33.01 | L+0.89 |
| 50-17 | 15.49 | 22.48 | 29.26 | 43.17 | L+0.89 |
| 85-13 | 12.04 | N/A | 22.52 | 33.01 | L-2.95 |
| 85-15 | 13.54 | N/A | 25.52 | 37.51 | L-2.95 |
| 85-21 | 18.48 | 26.93 | 35.26 | 53.71 | L-2.95 |
| 85-25 | 21.48 | 31.43 | 41.26 | 42.68 | L-2.95 |
| 85-27 | 22.98 | 33.69 | 44.27 | 67.22 | L-2.95 |
| 85-33 | 27.48 | 40.43 | 53.26 | 80.71 | L-2.95 |
| 100-21 | 18.48 | 26.93 | 35.26 | 53.71 | L-2.95 |
| 100-25 | 21.48 | 31.43 | 41.26 | 62.68 | L-2.95 |
| 100-27 | 22.98 | 33.69 | 44.27 | 67.22 | L-2.95 |
| 100-33 | 27.48 | 40.43 | 53.26 | 80.71 | L-2.95 |
| 125-25 | 22.09 | 31.88 | 41.98 | 63.29 | L-4.24 |
| 125-27 | 23.59 | 34.14 | 44.98 | 67.83 | L-4.24 |
| 125-33 | 28.09 | 40.88 | 53.98 | 81.32 | L-4.24 |

EXAMPLE:

If you are installing a DDM85 MULTI-STACK WITH ZERO SEPARATION and you have 21 plates/cell, 4 cells wide.

$$M \text{ (inches)} = L \text{ (in)} - 2.95''$$

$$35.26'' - 2.95'' = 32.31''$$

FRAME ASSEMBLY AND INSTALLATION

To assemble and install the frame for the PowerSafe® DDM battery system, follow the procedure below using the system layout determined in the "System Layout" section.

Base Beams

1. LEVEL with customer-supplied floor shims, and anchor in place. Do NOT torque anchor bolts until frame assembly is complete.
2. Install ALL base beams before continuing.

Vertical Channels

1. Insert vertical channels into base beams. See Figure 9.
2. Bolt vertical channels to base beams. Refer to below list for hardware order and Figure 10:
 - Serrated Hex Bolt (M10x1.5 – 100mm)
 - Rack Frame
 - External Tooth Washer
 - Flat Washer
 - Lock Washer
 - Hex Nut
3. Torque all connections (except anchor bolts) to 40 ft-lbs.

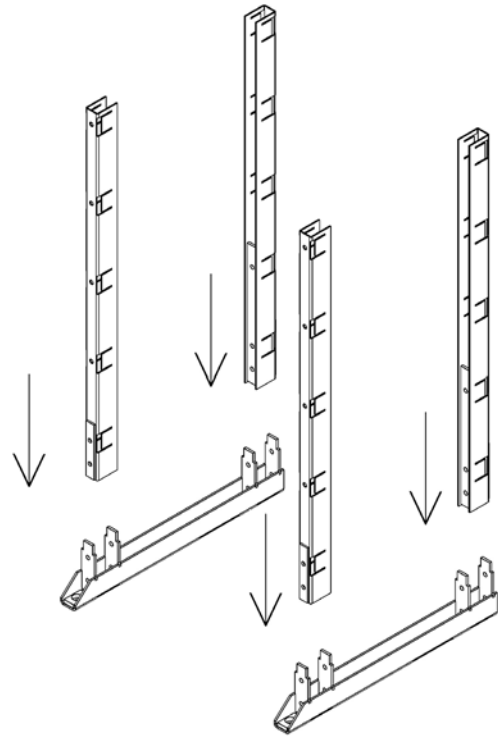

INSTALL VERTICALS
FIGURE 9

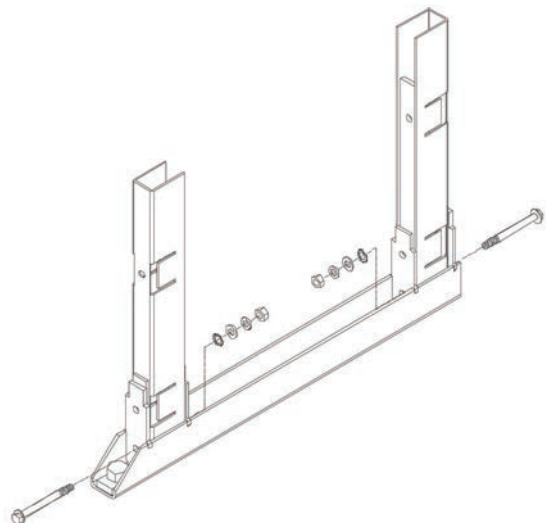

VERTICAL CHANNEL TO BASE
BEAM HARDWARE DETAIL
FIGURE 10

Horizontal Channels

Starting at the bottom of the rear verticals:

1. Insert horizontal channels into the vertical channels.
Center the horizontals between the verticals. See Figures 11A and 11B.
2. Bolt horizontal channels to vertical channels.
Refer to below list for hardware order and Figure 12:

NOTE:

The bottom two horizontal channels require full thread longer bolts at the vertical channel.

Bottom horizontal channel:

- Serrated Hex Bolt (M10x1.5 – 100mm Full Threads)
- Rack Frame
- External Tooth Washer
- Flat Washer
- Lock Washer
- Hex Nut

Second from bottom horizontal channel:

- Serrated Hex Bolt (M10x1.5 – 75mm Full Threads)
- Rack Frame
- External Tooth Washer
- Flat Washer
- Lock Washer
- Hex Nut

All other horizontals:

- Serrated Hex Bolt (M10x1.5 – 25mm)

3. Finger-tighten connections.
4. Install all rear horizontal channels before continuing.

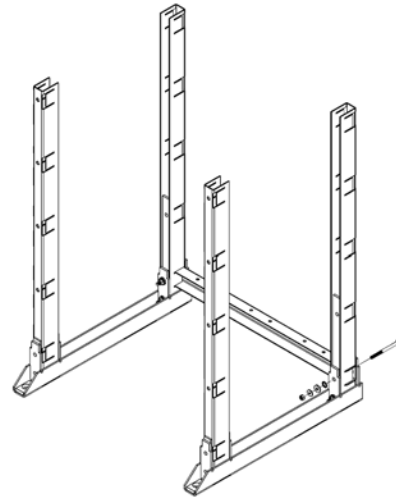

INSTALL REAR HORIZONTAL CHANNELS
FIGURE 11A

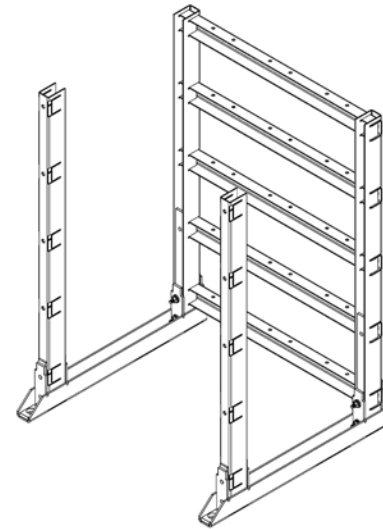

INSTALL REAR HORIZONTAL CHANNELS
FIGURE 11B

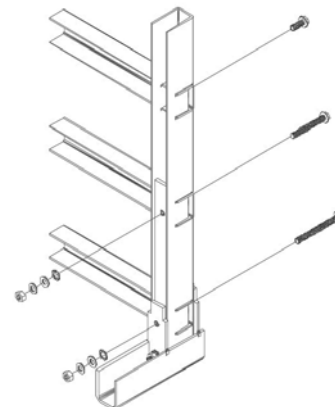

REAR HORIZONTAL CHANNEL HARDWARE DETAIL
FIGURE 12

Starting at the bottom of the front verticals:

1. Insert horizontal channels into the vertical channels.
Center the horizontals between the verticals. See Figures 13A and 13B.
2. Bolt horizontal channels to vertical channels.
Refer to below list for hardware order and Figure 14.

NOTE:

The bottom two horizontal channels require full thread longer bolts at the vertical channel.

Bottom horizontal channel:

- Serrated Hex Bolt (M10x1.5 – 100mm Full Threads)
- Rack Frame
- External Tooth Washer
- Flat Washer
- Lock Washer
- Hex Nut

Second from bottom horizontal channel:

- Serrated Hex Bolt (M10x1.5 – 75mm Full Threads)
- Rack Frame
- External Tooth Washer
- Flat Washer
- Lock Washer
- Hex Nut

All other horizontals:

- Serrated Hex Bolt (M10x1.5 – 25mm)

3. Finger-tighten connections.
4. Install all front horizontal channels before continuing.

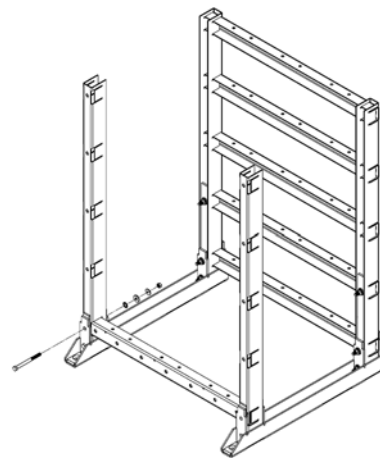

INSTALL FRONT HORIZONTAL CHANNELS
FIGURE 13A

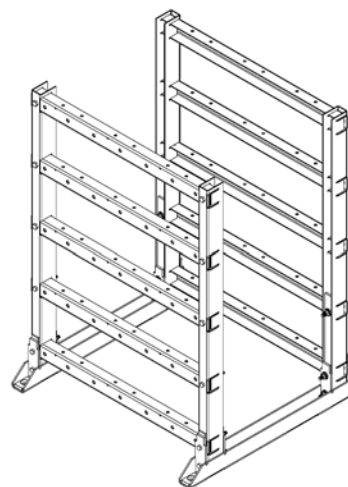

INSTALL FRONT HORIZONTAL CHANNELS
FIGURE 13B

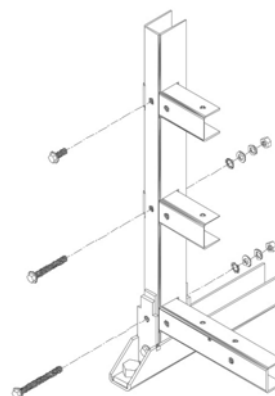

FRONT HORIZONTAL CHANNEL HARDWARE DETAIL
FIGURE 14

Cell Support Shelves

Starting at the bottom of the rack:

1. Place shelves over horizontals. See Figure 15.
2. Align holes of shelf with holes of horizontal channels. Bolt the shelf to the REAR horizontal using (two) M10x1.5 – 25mm Serrated Hex Bolts in the two OUTSIDE holes of the shelf. See Figure 16.
3. Torque these bolts to 20 ft-lbs.
4. After ALL shelves for the rack are in place, position the vertical channels so that the front and rear horizontals fit tightly against the shelves. See Figure 17.
5. Torque ALL bolts connecting the horizontals to the verticals to 20 ft-lbs.

NOTE:

MULTI-STACK WITH ZERO SEPARATION systems are fastened together at the top front and top rear with a steel tie bar/plate.

6. Torque all anchor bolts according to system design and manufacturer's recommendations.

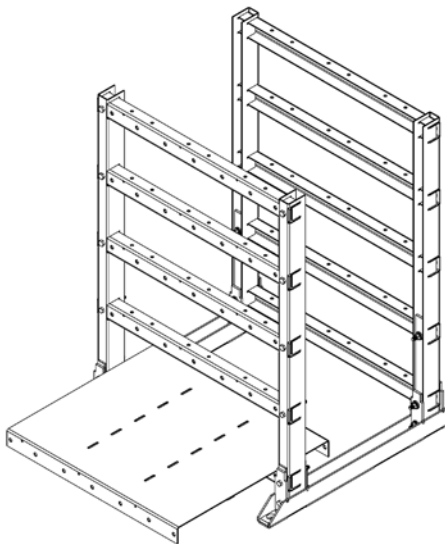

INSTALL BOTTOM CELL SUPPORT SHELF
FIGURE 15

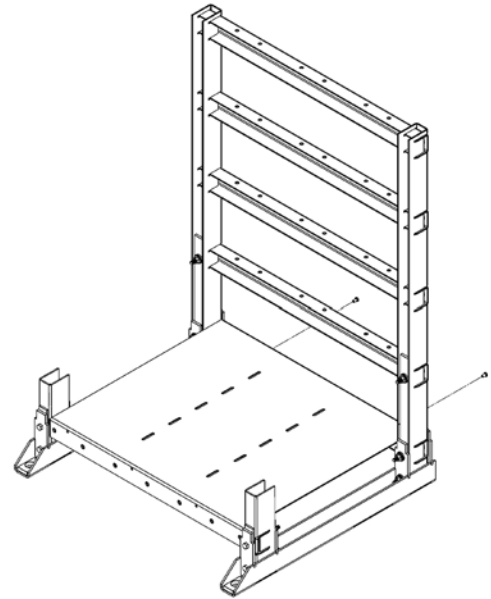

CELL SUPPORT SHELF REAR HARDWARE DETAIL
FIGURE 16

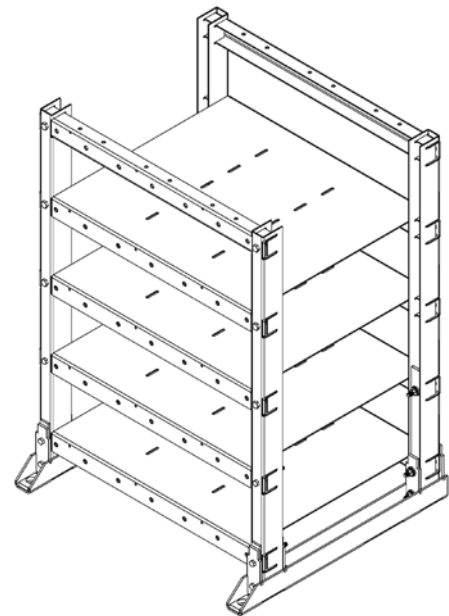

INSTALL CELL SUPPORT SHELVES
FIGURE 17

BATTERY CELL INSTALLATION

DDm battery cells are designed for shipment and use in steel modules.

USE CAUTION WHEN HANDLING THE DDm MODULES

After a cell has been inserted into a module at the factory, a loose fit could develop because of recombination. The cell could slip very easily from the module if the module/cell is turned so that the open end of the module is lower than the closed end of the module.

Serious personal injury could result if the cell slides unintentionally from the module. Keep shipping/installation retainer in place until modules are safely positioned on the shelves.

1. BEFORE installing the cells, check the voltages. The minimum acceptable cell voltage is 2.05 vpc. If a cell has a voltage below 2.05 vpc, call your nearest EnerSys® sales/service representative for resolution, or call the corporate office number listed on the back of this manual and ask for EnerSys Service.
2. Inspect each terminal for visual signs of mechanical defects.

NOTE:

Report any defects to your nearest EnerSys sales/service representative for resolution, or call the corporate office number listed on the back of this manual and ask for EnerSys Service.

If terminals are acceptable:

3. Place the FIRST DDm module onto the LOWEST EMPTY shelf, with the terminals toward the front. See Figure 18.

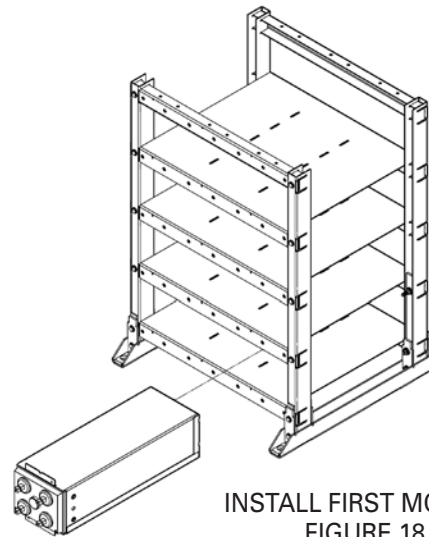

INSTALL FIRST MODULE
FIGURE 18

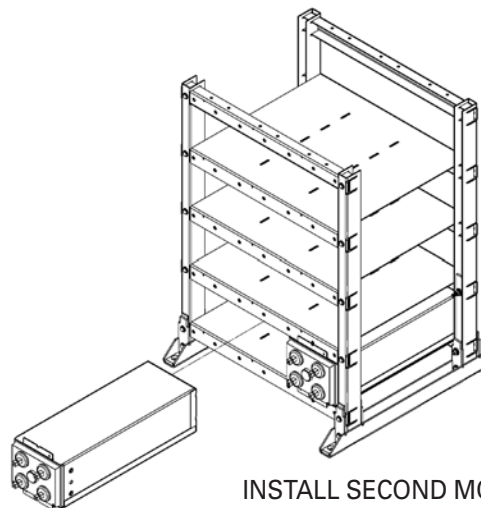

INSTALL SECOND MODULE
FIGURE 19

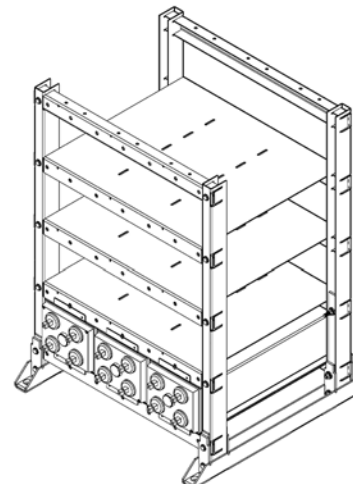

INSTALL MODULES
FIGURE 20

NOTE:

The larger modules are too heavy to lift onto the shelves manually. To avoid personal injury use appropriate lifting devices when lifting modules onto the shelves.

4. Slide the module back into a safe position. Remove the shipping retainer.
5. Slide module completely into position so the lip of the module touches the front of the shelf.
6. Place another cell onto the shelf next to the previously placed battery sleeve. Refer to the Assembly Drawing for the cell polarity configuration. See Figure 19.
7. Install remaining cells working from the lower shelves to the higher shelves. See Figures 20 and 21.

NOTE:

The top row of the rack requires spacers to be installed behind the upper lip of the battery modules. This spacer is fastened into place with the retainer and retainer bolt.

Module Retainers

1. For each battery module, install retainer plates and spacers as required, using a M10x1.5 – 25mm Serrated Hex Bolt. See Figure 22.
2. Torque to 20 ft-lbs.

Electrical Bonding Instructions

1. For each battery module, install one M6 Self-Tapping Screw through front lip of the battery module into the shelf/horizontal channel. See Figure 23.
2. For each retainer spacer, install one M6 Self-Tapping Screw through the spacer into the horizontal channel. See Figure 23.

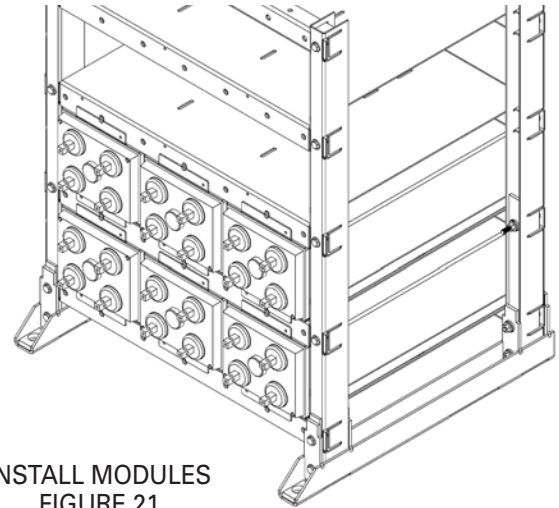

INSTALL MODULES
FIGURE 21

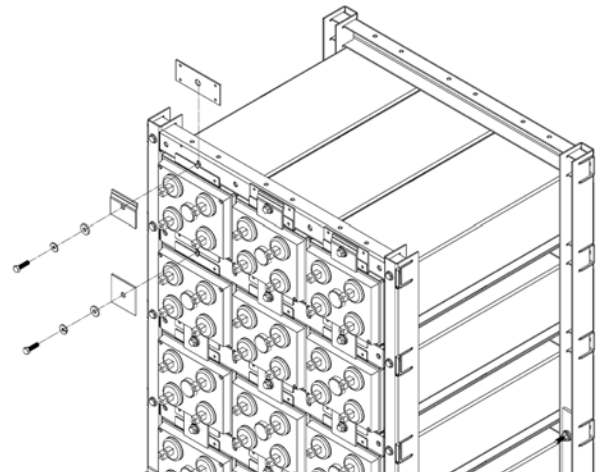

INSTALL RETAINERS
FIGURE 22

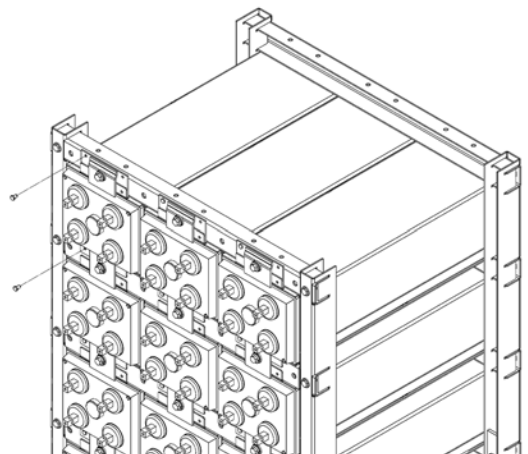

INSTALL BONDING SCREW
FIGURE 23

CONNECTIONS

The cells are now positioned and ready to be connected. The cells must be connected according to the polarities on the ASSEMBLY DRAWING and the following instructions.

Before preparing and making connections, heat NO-OX-ID grease in hot water as necessary to soften for application with a paintbrush.

Terminal Plates

Terminal plates are provided with the battery system to provide a system connections point. All system connections must be made to the terminal plate and NEVER to the cell terminal. Top termination is standard, on most configurations, side termination is optional.

1. Clean the terminal plate electrical contact areas with a stiff-bristle nonmetallic brush/pad until the plated surface is bright. Be careful not to remove the plating with excessive brushing.
2. Apply a light coat of heated NO-OX-ID grease to the terminal plate electrical contact area with a small paintbrush.
3. Assemble and install the terminal plate assembly finger-tight as shown in Figure 24.
4. Check for alignment with cell terminal.
5. Torque all bolts to 15 ft-lbs.

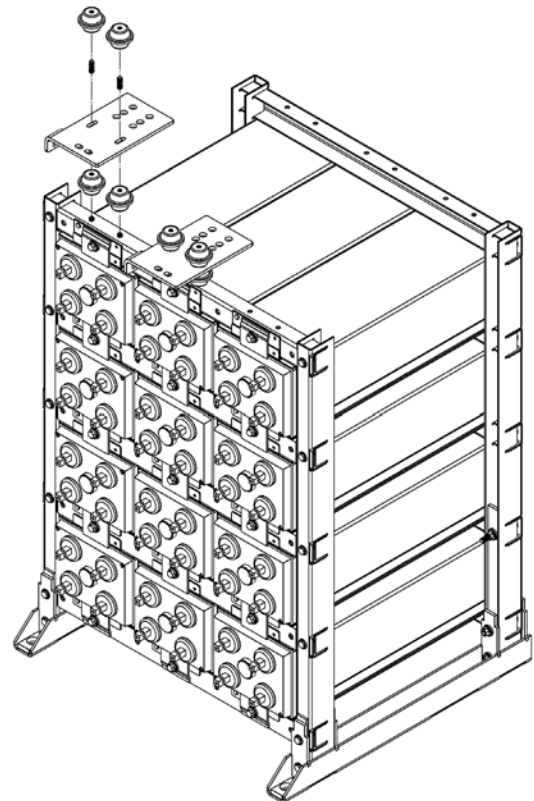

INSTALL TERMINAL PLATES
FIGURE 24

Inter-Cell Connectors

The connections are made by bolting the supplied plated copper inter-cell and intermodule connectors to the cell posts of opposite polarity on adjacent cells. See ASSEMBLY DRAWING for details.

1. Clean the contact surface of the inter-cell connector using a stiff-bristle nonmetallic brush/pad. Be careful not to remove the plating with excessive brushing.
2. Apply a light coat of heated NO-OX-ID grease to the contact surface of the inter-cell connector and terminal post with a small paintbrush.
3. Bolt all inter-cell connectors according to the ASSEMBLY DRAWING. Assemble as the example shown in Figure 25 and below list:

NOTE:

Stamped flat washers may have one sharp edge. Install the washer with the sharp edge away from the plated copper inter-cell connector to avoid damaging the plating

- Hex Bolt
- Flat Washer
- Connector
- Battery Post
- Connector
- Flat Washer
- Lock Washer
- Hex Nut

NOTE:

Inter-cell connections vary in length depending on the type of connection (cell-to-cell, module-to-module, etc.) and/or stack configuration.

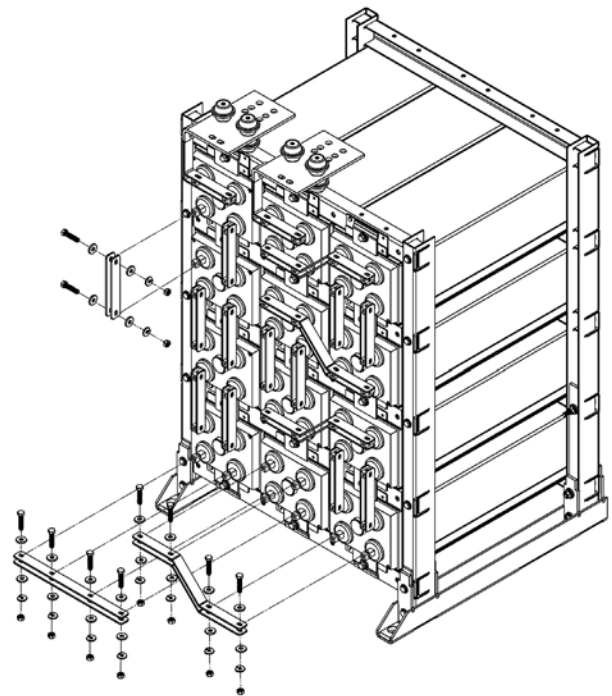

INSTALL INTER-CELL CONNECTORS
FIGURE 25

4. Secure all connections finger-tight to allow for some adjustment of position.
5. After all connections are completed, torque all to 85 in-lbs.
6. Apply a light coat of heated NO-OX-ID grease to the bolted connection with a small paintbrush.

Terminal Bars

Terminal bars are supplied with the battery system to provide a cell terminal-to-terminal plate connection.

1. Inspect the system to be assured that all cells are connected correctly – POSITIVE to NEGATIVE and according to the ASSEMBLY DRAWING.
2. Clean the terminal bar contact area with a stiff-bristle nonmetallic brush/pad until the plated surface is bright. Be careful not to remove the plating with excessive brushing.
3. Apply a light coat of heated NO-OX-ID grease to the terminal bar contact area with a small paintbrush.
4. Install terminal bars as shown in Figure 26.
5. Torque bolts to 85 in-lbs.
6. Apply a light coat of heated NO-OX-ID grease to the bolted connections with a small paintbrush

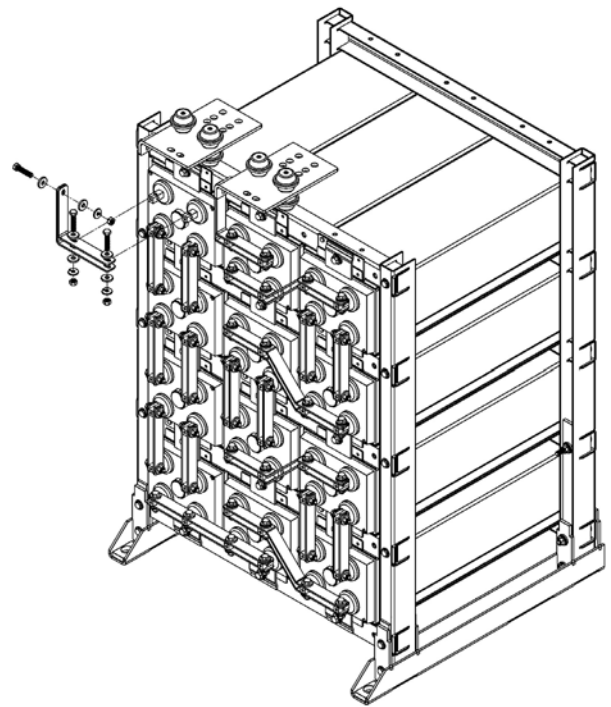

INSTALL TERMINAL BARS
FIGURE 26

INITIAL SYSTEM READINGS

Measure the DC system voltage across the system terminals. Voltage should equal approximately 2.15 times the number of cells in the system (See Table 3).

If the voltage is lower than 2.15 times the number of cells in the system, inspect the system to be assured that all cells are connected correctly - POSITIVE to NEGATIVE and according to the ASSEMBLY DRAWING.

| TABLE 3 APPROXIMATE VOLTAGE | |
|--|---------------------------------|
| Number of Cells | (2.15 x number of cells) |
| 12 | 25.8 |
| 24 | 51.6 |

If the voltage is persistently lower than 2.15 times the number of cells in the system, contact your EnerSys sales/service representative, or call the corporate office number listed on the back of this manual and ask for EnerSys Service.

Make a copy of the Battery maintenance Report found in the Safety, Storage, Operating and Maintenance Manual. Measure and record the connection resistance of "CELL to CELL" and "CELL to TERMINAL" on the report.



CAUTION:

Connections made to a battery for tapping a certain group of cells to provide a voltage other than the total battery voltage is NOT recommended and can VOID THE WARRANTY. It can affect the serviceability of the battery. Tapping results in an imbalance of the system during charging and discharging a unsatisfactory operation.

SAFETY SHIELDS AND COVERS

Safety shields and covers are provided to help prevent accidental contact with connections after installation and during operations. Safety shields and covers should remain in place at all times during normal operation of the system. Terminal plate covers are provided as necessary to prevent accidental contact with the "live" terminal plate. Safety shields are designed to be removed for service or maintenance.

Safety Shields

1. Install ALL safety shield support posts into horizontals as shown in Figure 27.
2. Starting with bottom row, hang safety shields on support posts as shown in Figure 28.

NOTE:

The bottom of each safety shield will overlap, on the outside, the top of the shield below it.

Terminal Plate Covers

1. Connect load to the battery terminal.
2. Install terminal plate covers as shown in Figure 29.

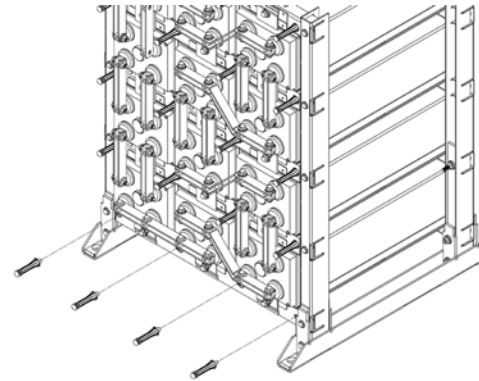

INSTALL SUPPORT POSTS
FIGURE 27

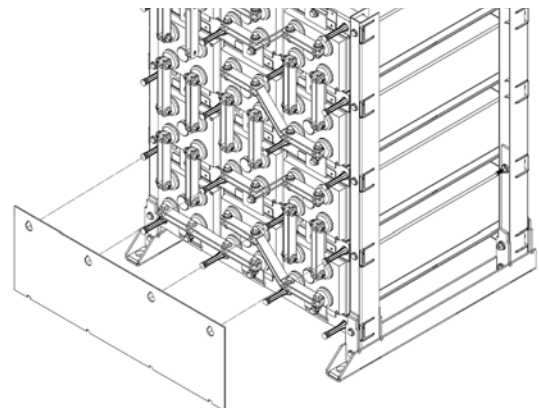

INSTALL SAFETY SHIELDS
FIGURE 28

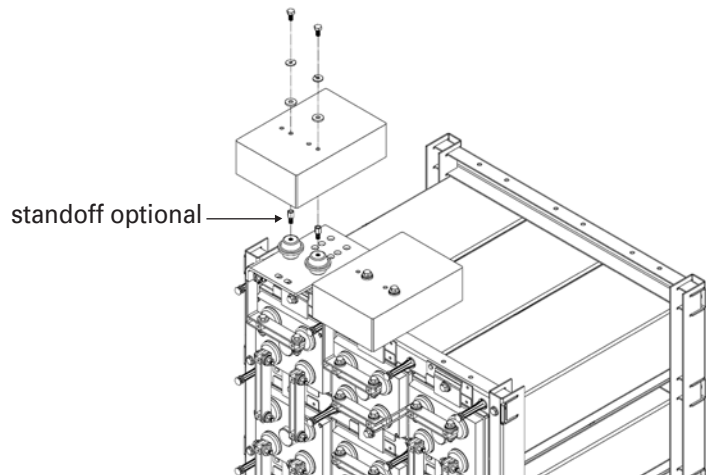

INSTALL TERMINAL PLATE COVER
FIGURE 29



www.enersys.com

EnerSys World Headquarters 2366 Bernville Road, Reading, PA 19605, USA Tel: +1-610-208-1991 / +1-800-538-3627

EnerSys EMEA EH Europe GmbH, Baarerstrasse 18, 6300 Zug, Switzerland

EnerSys Asia 152 Beach Road, Gateway East Building #11-03, Singapore 189721 Tel: +65 6508 1780

© 2016 EnerSys. All rights reserved.

Trademarks and logos are the property of EnerSys and its affiliates unless otherwise noted.

Subject to revisions without prior notice. E.&O.E.

Publication No: US-DDM-IM-AA June 2016